



Rocla

ecoSep[®]
Oil-water separator

131 004
rocla.com.au

EcoSep®

The Rocla ecoSep® oil-water separator is a below grade device that permanently separates oil from water.

The system provides cost effective, high efficiency elimination of sediments and oil from point source run off (such as floor drains) and non point source stormwater run off from industrial areas (such as refuelling depots and maintenance facilities).

The performance of Rocla ecoSep® oil-water separator has been proven by independent testing authorities to exceed the strict European standards for the separation of free non-emulsified oil from water (5ppm separation ratios).

Standard units are available in flow rates of 3, 10 and 20l/s with custom designed units to 100l/s.

The system is normally supplied as a two tank design. The first precast concrete chamber removes grit and other solids.

The second chamber separates oil from the water through a combination of gravity and the coalescing separator. This chamber also contains the Rocla ecoStop® spill control system to contain catastrophic spills.

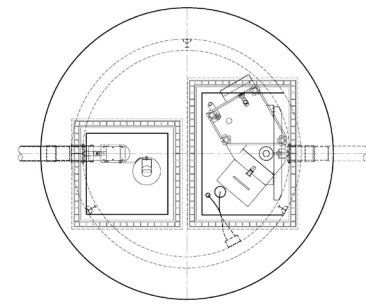
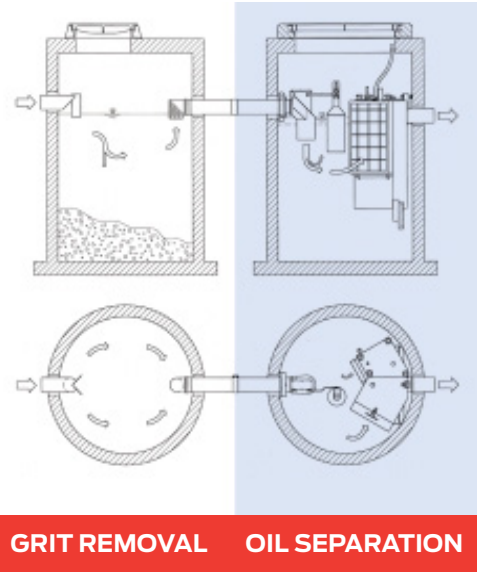

Figure: Large access covers for ecoSep® oil-water separator

FEATURES

- Permanently separates oil from water
- Complies with European Standard EN858 for control of free oil
- Automatic hydrocarbon spill control
- Separates light liquids (specific gravity below 0.95)
- Separates free oils to less than 5ppm in discharge
- High operational reliability
- All stainless steel internal components
- High quality precast concrete chambers
- Low maintenance and waste disposal costs

Annual maintenance costs can be substantially reduced compared with conventional separator systems.

Large access covers are provided with the system, facilitating routine cleaning and maintenance. The openings and covers are designed to optimise safe access for key internal components, such as the inlet float and coalescing media cartridge.

All internal stainless steel components are factory installed in high quality precast concrete chambers.

THE IDEAL OIL-WATER SEPARATION SOLUTION FOR:

- Fuelling facilities, transformers and oil storage areas
- Treatment of non-detergent washing water from vehicle washing and repair workshops
- Treatment of industrial process waste water
- Treatment of waste water from oil removal plants
- Purification upstream from emulsion breakers and micro filtration units

Product	Model	Code	Inlet DN (mm)	Outlet DN (mm)	Outlet Min. DTI (mm)	Chamber DN (mm)	Nom Oil Storage L	Operating Volume L
EcoStop®	100	ECS10C	100	100	590	1200	260	1600
	150	ECS15C	150	150	660	1500	400	2900
	200	ECS20C	225	225	820	1800	580	3950

Product	Model	Code	Max Flow (L/sec)	Inlet DN (mm)	Outlet DN (mm)	Outlet Min. DTI (mm)	Chamber DN (mm)	Nom Oil Storage (Litres)	Operating Volume (Litres)
EcoSep®	NS03	ECE03C	3	100	100	590	1200	260	1600
	NS10	ECE10C	10	150	150	660	1500	400	2900
	NS20	ECE20C	20	225	225	820	1800	580	3950

THREE-STAGE WATER PURIFICATION

Rocla ecoSep® oil-water separator makes optimum use of three purification methods:

1. Sedimentation
2. Gravity oil-water separation
3. Final effluent polishing in a residual oil coalescing medium

The accumulated oil can be continuously removed with the addition of an automatic oil draw-off device, saving disposal costs and avoiding emulsification.

STEP 1: GRIT REMOVAL

The first, upstream grit chamber removes solids from the influent. A perforated 90-degree outlet tube prevents floating solids from entering the separation chamber.

STEP 2: GRAVITY SEPARATION OF OIL

The oil-water mixture is then admitted to the second (separation) chamber. The mixture enters the chamber through the Rocla ecoStop® spill control system, which closes automatically in the event of a catastrophic spill. In the separation chamber, the light liquids (specific gravity below 0.95) float to the surface.



STEP 3: COALESCING OF RESIDUAL OIL

Fine oil droplets that are too small to be separated by gravity then pass through the coalescing medium in the Rocla ecoSep® oil-water separator.

The coalescing medium is a net-like polyurethane foam that accumulates the droplets into larger drops that can rise to the surface. The separated water leaving the system has a residual free petroleum content of less than 5mg/l (5ppm).

HOW IT WORKS

The ecoSep® outlet structure also contains an oil storage chamber which allows accumulated hydrocarbons to be stored.

As hydrocarbons accumulate on the water surface they can be manually drawn away by opening a valve and allowing the oil to drain into an independent storage chamber.

The oil passes through a piece of coalescing media on the inlet to the valve, further refining it.

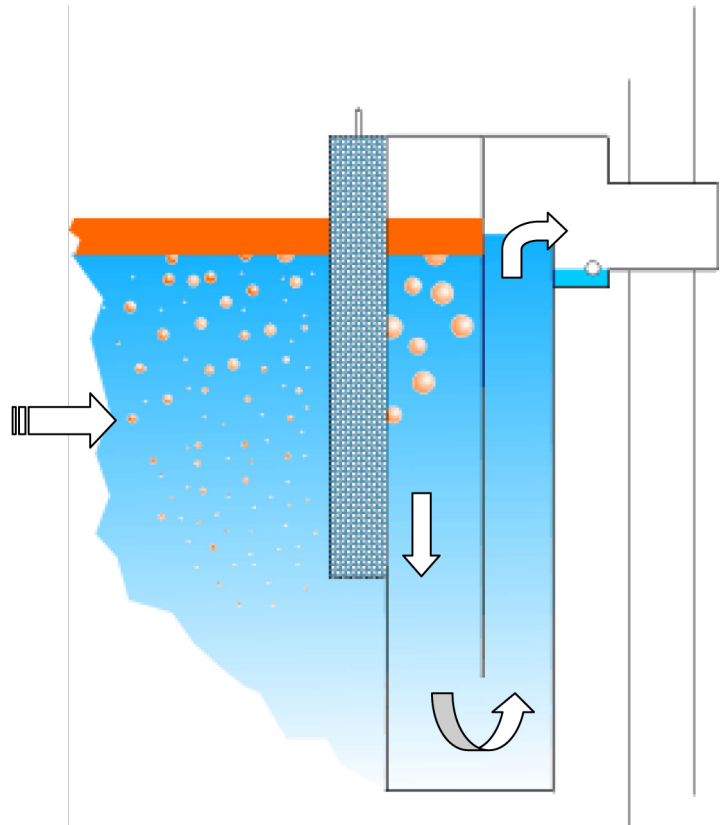

Figure: ecoSep® Coalescing Separation

ECOSTOP®

Rocla ecoStop® spill control system is a secure and reliable hydrocarbon spill management system suitable for any site with a potential for spills. As the system detects and responds to spills automatically, it minimises the chances of failures caused by human error.

The system is installed in a precast concrete chamber, downstream from a segregated hydrocarbon containment drainage area. The float actuated shut-off valve stops flow through the system when maximum hydrocarbon storage capacity or a certain liquid level is reached, preventing the discharge of free hydrocarbon to municipal sewers or direct discharge outfalls.

Rocla ecoStop® spill control system maintains the spill on site where it can be contained either below grade (in an underground storage tank or large diameter pipe) or above grade in a bunded area.

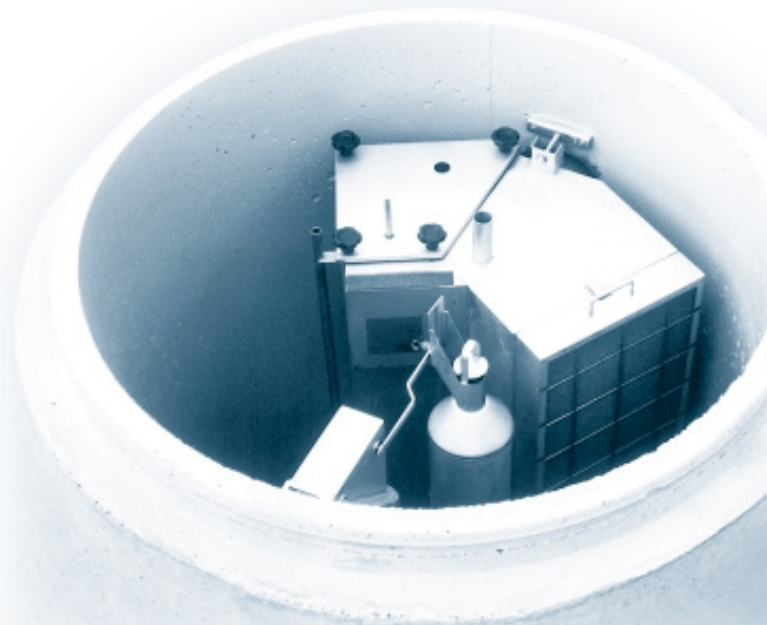

AUTOMATIC DRAW-OFF DEVICE (ADD)

The ADD is an add-on device that constantly removes accumulated light liquid from the water surface to be stored in a separate oil vessel.

In the first chamber oil is once again separated from water and builds up a layer on the surface of the water.

Due to the height difference only light liquid can be discharged to the oil vessel. When the maximum level in the oil vessel is reached, a float closes the inlet valve of the ADD.

The second float controls the water level in the separator and closes the inlet and outlet valve of the ADD when the water level in the separator rises.

These valves ensure that the oil collected in the tank cannot be mixed with water once again.

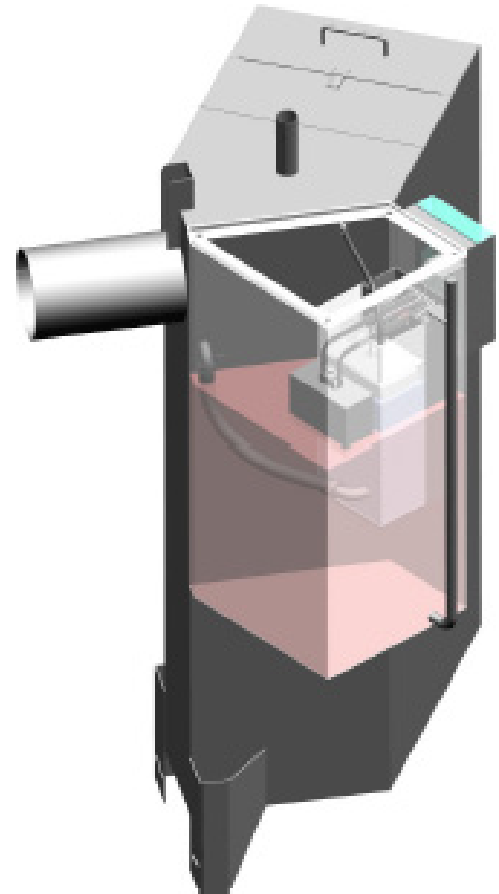

Figure: ADD with ecoSep® Oil Storage Chamber

ECOWARN®

The ecoWarn® is an alarm device used to monitor the depth of accumulated oil within the separator and warns operators when spills have occurred.

The device uses two probes to monitor the oil/water level within the chamber as well as the oil depth.

The high level probe will activate in both oil and water and is designed to warn maintenance staff when the ecoStop® valve has been actuated or when the system is malfunctioning.



For more
information
call Rocla on
131 004 or visit
rocla.com.au

CONCRETE PRODUCTS | PIPE | ENGINEERING CAPABILITY



The information contained within this brochure is intended as a guide for information only and is subject to change without notice. Rocla does not invite any person to act or rely upon such information.

Before application in a particular situation, Rocla recommends that you obtain appropriate independent qualified expert advice confirming the suitability of product(s) and information in question for the application proposed.

To the extent permitted by law, Rocla disclaims all liability (including liability for negligence) for all loss and damage resulting from the direct or indirect use, or reliance on, the information provided in this brochure.

First Defense® is a trademark of Hydro International Plc used under license. ® and ™ are trademarks of Rocla Pty Limited ABN 31 000 032 191

